



司騰達股份有限公司  
BHP Industry Solution

PROFI  
NET

EtherCAT

EtherNet/IP

CC-Link

Modbus

PROFI  
BUS

CANopen

Hms  
Connecting Devices



Now with ...  
OPC UA



DeviceNet

WiFi



# 司騰達股份有限公司

APPD / IPPD 工業級觸控螢幕

司騰達公司致力於推廣數位化工廠和 IIoT 工業物聯網的解決方案，並與歐洲最先進的公司 – HMS 集團合作，同時透過引進更多歐美的技術能量，提供客戶關於工業 4.0 的顧問諮詢服務，並將教育與產業連結，協助台灣產業逐步完成從現場設備、生產資訊、通訊 IoT 的垂直整合，並整合 M2M 工業總線與軟體開發，從而實現數位化工廠與自動化機械領域的創新。



司騰達聯絡訊息

臺北客服專線：(02)-2242-1625

台中客服專線：(04)-2451-0611

客服信箱：sales@bhp.com.tw

Line ID：@bhp.tw

www.bhp.com.tw

# JM-APPD1205T

12.1" IP65 Industrial 4:3 XGA LCD Flush Touch Monitor



## Main Features

- ♦ IP65 compliant plastic front bezel with flush panel by 5-wire touch screen
- ♦ Dual display input interface: analog VGA and DVI-D
- ♦ Shares identical appearance with APPC series
- ♦ Dual touch screen interface: RS232 and USB
- ♦ Ultra slim in depth
- ♦ OSD multilanguage function

## Product Overview

12.1" 4:3 LCD display APPD 1205T is based on a 5-wire resistive touch screen. It has 500 nits brightness and can support resolutions up to 1024 x 768. APPD 1205T is ideal for space-critical environments where systems and displays are kept apart. In addition, APPD 1205T adopts a flush panel design and has IP65 front panel. APPD 1205T provides prevailing video interfaces: VGA and DVI, supporting both digital and analog signals; touch screen can be connected with RS232 or USB ports. Moreover, APPD 1205T supports 12~24VDC power input and offers panel mount and VESA mount, allowing users to choose the mounting method that meets their situation. APPD 1205T is the best solution for NEXCOM NISE fanless computer, NVIS security surveillance series and APPC panel PC when a second display is required.

## Specifications

### Panel

- ♦ LCD size: 12.1", 4:3
- ♦ Resolution: XGA 1024 x 768
- ♦ Luminance: 500cd/m<sup>2</sup>
- ♦ Contrast ratio: 700
- ♦ LCD color: 16.7M
- ♦ Viewing angle: 70 (U), 70 (D), 80 (L), 80 (R)
- ♦ Backlight: LED

### Touch Screen

- ♦ 5-Wire resistive (flush panel type)
- ♦ Light transmission: 80%
- ♦ Interface: USB and RS232

### Rear I/O

- ♦ Touch screen interface port: RS-232 (1 x DB9)/USB type A
- ♦ Video port: VGA (1 x DB15)/DVI-D (1 x DVI-I connector)
- ♦ DC power input connector: 3-pin Phoenix terminal Blocks

### OSD Function

- ♦ OSD keypad
- ♦ Multilanguage OSD

### Mechanical & Environment

- ♦ Color: Pantone black and black silver chassis box
- ♦ IP protection: IP65 front
- ♦ Mounting: panel/wall/stand/VESA 100mm x 100mm
- ♦ Power
  - Power input: 12V~24VDC
  - Power adapter: optional AC to DC power adapter (+12V, 60W)
- ♦ Vibration
  - IEC 68 2-64
  - 2Grms @ sine, 5~500Hz, 1hr/axis (operating)
  - 2.2Grms @ random condition, 5~500Hz, 0.5hr/axis (non-operating)
- ♦ Shock
  - IEC 68 2-27
  - 20G@wall mount, half sine, 11ms
  - Operating temperature: -5°C~50°C
  - Storage temperature: -20°C~75°C
- ♦ Operating humidity: 10%~90% relative humidity, non-condensing
- ♦ Dimension: 317 x 243 x 53.5mm
- ♦ Weight: 2.8 kg

### Certifications

- ♦ CE approval
- ♦ FCC Class B

## Dimension Drawing

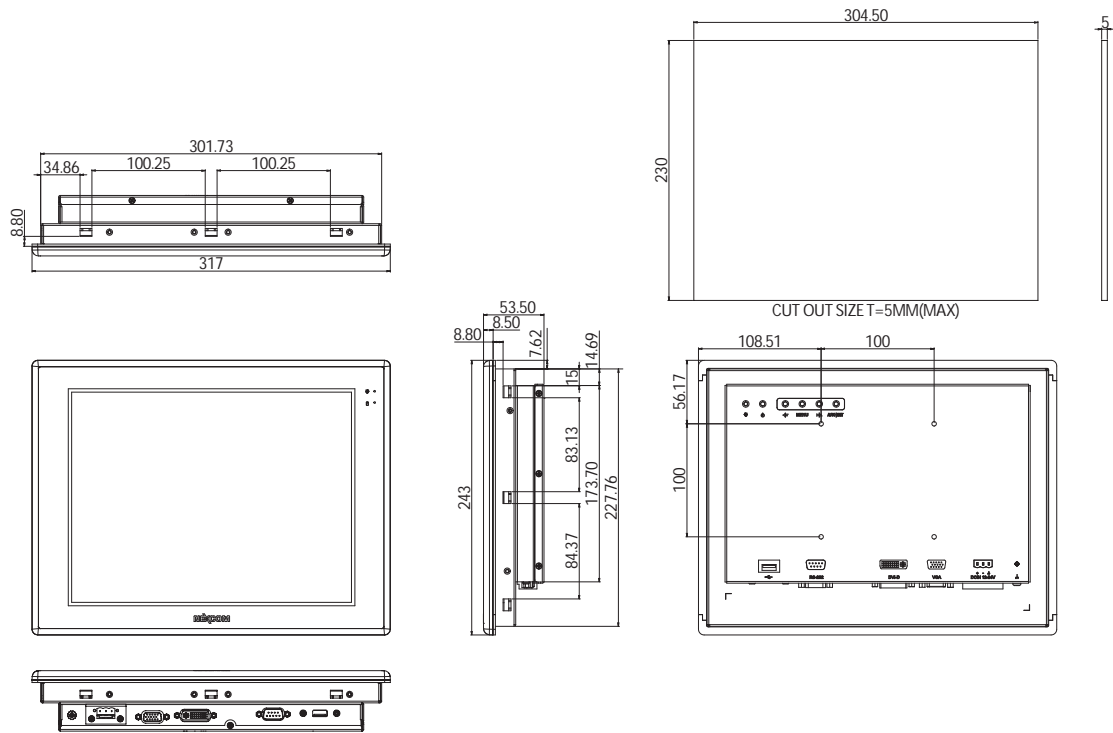

## Ordering Information

### •JM-APPD1205T

12.1" XGA industrial 4:3 TFT LED backlight flush touch monitor with VGA and DVI-D input, 12~24VDC input, RS-232 and USB touch screen interfaces

### Options

•12V, 60W AC/DC power adapter w/o power cord

(P/N: 7400060031X00)

•1.8m DVI-D male to DVI-D male cable

(P/N: 603DVI0007X00)

型號 : JM-APPD1205T

# JM-APPD1500T

15" IP65 Industrial 4:3 XGA LCD Flush Touch Monitor



## Main Features

- ♦ IP65 compliant plastic front bezel with flush panel by 5-wire touch screen
- ♦ Dual display input interface: analog VGA and DVI-D
- ♦ Shares identical appearance with APPC series
- ♦ Dual touch screen interface: RS232 and USB
- ♦ Ultra slim in depth
- ♦ OSD multilanguage function

## Product Overview

15" 4:3 LCD display APPD 1500T is based on a 5-wire resistive touch screen. It has 500 nits brightness and can support resolutions up to 1024 x 768. APPD 1500T is ideal for space-critical environments where systems and displays are kept apart. In addition, APPD 1500T adopts a flush panel design and has IP65 front panel. APPD 1500T provides prevailing video interfaces: VGA, DVI and DisplayPort, supporting both digital and analog signals; touch screen can be connected with RS-232 or USB ports. Moreover, APPD 1500T supports 12~24VDC power input and offers panel mount and VESA mount, allowing users to choose the mounting method that meets their situation. APPD 1500T is the best solution for NEXCOM NISE fanless computer, NVIS security surveillance series and APPC panel PC when a second display is required.

## Specifications

### Panel

- ♦ LCD size: 15", 4:3
- ♦ Resolution: XGA 1024 x 768
- ♦ Luminance: 400cd/m<sup>2</sup>
- ♦ Contrast ratio: 2500
- ♦ LCD color: 16.7M
- ♦ Viewing angle: 88 (U), 88 (D), 88 (L), 88 (R)
- ♦ Backlight: LED

### Touch Screen

- ♦ 5-Wire resistive (flush panel type)
- ♦ Light transmission: 81%
- ♦ Interface: USB and RS232

### Rear I/O

- ♦ Touch screen interface port: RS-232 (1 x DB9)/USB type A
- ♦ Video port: VGA (1 x DB15)/DVI-D (1 x DVI-H connector)
- ♦ DC power input connector: 3-pin Phoenix terminal blocks

### OSD Function

- ♦ OSD keypad
- ♦ Multilanguage OSD

### Mechanical & Environment

- ♦ Color: Pantone black and black silver chassis box
- ♦ IP protection: IP65 front
- ♦ Mounting: panel/wall/stand/VESA 100mm x 100mm
- ♦ Power
  - Power input: 12V~24VDC
  - Power adapter: optional AC to DC power adapter (+12V, 60W)
- ♦ Vibration
  - IEC 68 2-64
  - 2Grms @ sine, 5~500Hz, 1hr/axis (operating)
  - 2.2Grms @ random condition, 5~500Hz, 0.5hr/axis (non-operating)
- ♦ Shock
  - IEC 68 2-27
  - 20G@wall mount, half sine, 11ms
  - Operating temperature: -5°C~50°C
  - Storage temperature: -20°C~75°C
- ♦ Operating humidity: 10%~90% relative humidity, non-condensing
- ♦ Dimension: 384.37 x 309.95 x 51mm
- ♦ Weight: 3.9 kg

### Certifications

- ♦ CE approval
- ♦ FCC Class B

## Dimension Drawing

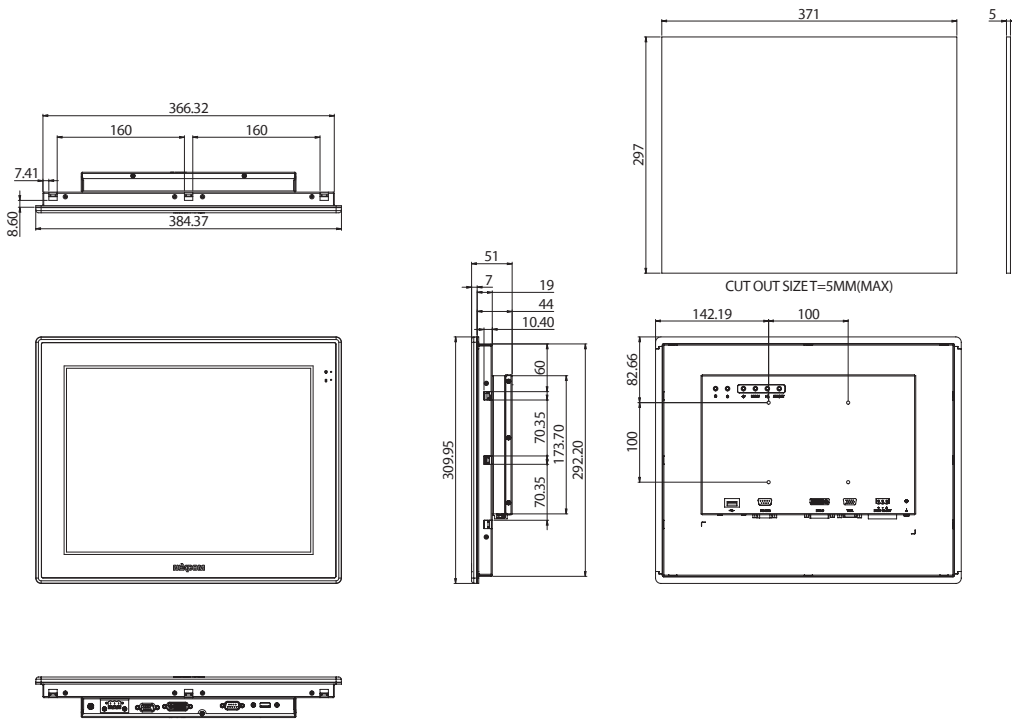

## Ordering Information

### ♦JM-APPD1500T

15" XGA industrial 4:3 LED backlight flush touch monitor with VGA and DVI-D input, 12~24VDC input, RS232 and USB touch screen interfaces

### Options

♦12V, 60W AC/DC power adapter w/o power cord  
(P/N: 7400060031X00)

♦1.8m DVI-D male to DVI-D male cable  
(P/N: 60233DVI28X00 or P/N: 603DVI0007X00)

型號 : JM-APPD1500T

# JM-APPD1700T

17" IP65 Industrial 4:3 SXGA LCD Flush Touch Monitor



## Main Features

- ♦ IP65 compliant plastic front bezel with flush panel by 5-wire touch screen
- ♦ Dual display input interface: analog VGA and DVI-D
- ♦ Shares identical appearance with APPC series
- ♦ Dual touch screen interface: RS232 and USB
- ♦ Ultra slim in depth
- ♦ OSD multilanguage function

## Product Overview

17" 4:3 LCD display APPD 1700T is based on a 5-wire resistive touch screen. It has 350 nits brightness and can support resolutions up to 1280 x 1024. APPD 1700T is ideal for space-critical environments where systems and displays are kept apart. In addition, APPD 1700T adopts a flush panel design and has IP65 front panel. APPD 1700T provides prevailing video interfaces: VGA and DVI, supporting both digital and analog signals; touch screen can be connected with RS232 or USB ports. Moreover, APPD 1700T supports 12~24VDC power input and offers panel mount and VESA mount, allowing users to choose the mounting method that meets their situation. APPD 1700T is the best solution for NEXCOM NISE fanless computer, NVIS security surveillance series and APPC panel PC when a second display is required.

## Specifications

### Panel

- ♦ LCD size: 17", 4:3
- ♦ Resolution: SXGA 1280 x 1024
- ♦ Luminance: 350cd/m<sup>2</sup>
- ♦ Contrast ratio: 800
- ♦ LCD color: 16.7M
- ♦ Viewing angle: 60 (U), 80 (D), 80 (L), 80 (R)
- ♦ Backlight: LED

### Touch Screen

- ♦ 5-Wire resistive (flush panel type)
- ♦ Light transmission: 81%
- ♦ Interface: USB and RS232

### Rear I/O

- ♦ Touch interface port: RS232 (1 x DB9)/USB type A
- ♦ Video port: VGA (1 x DB15)/DVI-D (1 x DVI-H connector)
- ♦ DC power input connector: 3-pin Phoenix terminal blocks

### OSD Function

- ♦ OSD keypad
- ♦ Multilanguage OSD

### Mechanical & Environment

- ♦ Color: Pantone black and black silver chassis box
- ♦ IP protection: IP65 front
- ♦ Mounting: panel/wall/stand/VESA 100mm x 100mm
- ♦ Power
  - Power input: 12V~24VDC
  - Power adapter: optional AC to DC power adapter (+12V, 60W)
- ♦ Vibration
  - IEC 68 2-64
  - 2Grms @ sine, 5~500Hz, 1hr/axis (operating)
  - 2.2Grms @ random condition, 5~500Hz, 0.5hr/axis (non-operating)
- ♦ Shock
  - IEC 68 2-27
  - 20G@wall mount, half sine, 11ms
  - Operating temperature: -5°C~50°C
  - Storage temperature: -20°C~75°C
- ♦ Operating humidity: 10%~90% relative humidity, non-condensing
- ♦ Dimension: 410.4 x 340.4 x 53.9mm
- ♦ Weight: 4.8 kg

### Certifications

- ♦ CE approval
- ♦ FCC Class B



# JM-APPD1900T

19" IP65 Industrial 4:3 SXGA LCD Flush Touch Monitor



## Main Features

- ♦ IP65 compliant plastic front bezel with flush panel by 5-wire touch screen
- ♦ Dual display input interface: analog VGA and DVI-D
- ♦ Shares identical appearance with APPC series
- ♦ Dual touch screen interface: RS232 and USB
- ♦ Ultra slim in depth
- ♦ OSD Multilanguage function

## Product Overview

19" 4:3 LCD display APPD 1900T is based on a 5-wire resistive touch screen. It has 350 nits brightness and can support resolutions up to 1280 x 1024. APPD 1900T is ideal for space-critical environments where systems and displays are kept apart. In addition, APPD 1900T adopts a flush panel design and has IP65 front panel. APPD 1900T provides prevailing video interfaces: VGA and DVI, supporting both digital and analog signals; touch screen can be connected with RS232 or USB ports. Moreover, APPD 1900T supports 12~24VDC power input and offers panel mount and VESA mount, allowing users to choose the mounting method that meets their situation. APPD 1900T is the best solution for NEXCOM NISE fanless computer, NVIS security surveillance series and APPC panel PC when a second display is required.

## Specifications

### Panel

- ♦ LCD size: 19", 4:3
- ♦ Resolution: SXGA 1280 x 1024
- ♦ Luminance: 350cd/m<sup>2</sup>
- ♦ Contrast ratio: 1000
- ♦ LCD color: 16.7M
- ♦ Viewing angle: 80 (U), 80 (D), 85 (L), 85 (R)
- ♦ Backlight: LED

### Touch Screen

- ♦ 5-Wire resistive (flush panel type)
- ♦ Light transmission: 81%
- ♦ Interface: USB and RS232

### Rear I/O

- ♦ Touch interface port: RS-232 (1 x DB9)/USB type A
- ♦ Video port: VGA (1 x DB15)/DVI-D (1 x DVI-I connector)
- ♦ DC power input connector: 3-pin Phoenix terminal blocks

### OSD Function

- ♦ OSD keypad
- ♦ Multilanguage OSD

### Mechanical & Environment

- ♦ Color: Pantone black and black silver chassis box
- ♦ IP protection: IP65 front
- ♦ Mounting: panel/wall/stand/VESA 100mm x 100mm
- ♦ Power
  - Power input: 12V~24VDC
  - Power adapter: optional AC to DC power adapter (+12V, 60W)
- ♦ Vibration
  - IEC 68 2-64
  - 2Grms @ sine, 5~500Hz, 1hr/axis (operating)
  - 2.2Grms @ random condition, 5~500Hz, 0.5hr/axis (non-operating)
- ♦ Shock
  - IEC 68 2-27
  - 20G@wall mount, half sine, 11ms
  - Operating temperature: -5°C~50°C
  - Storage temperature: -20°C~75°C
- ♦ Operating humidity: 10%~90% relative humidity, non-condensing
- ♦ Dimension: 457.64 x 379.24 x 49.15mm
- ♦ Weight: 5.5 kg

### Certifications

- ♦ CE approval
- ♦ FCC Class B

## Dimension Drawing

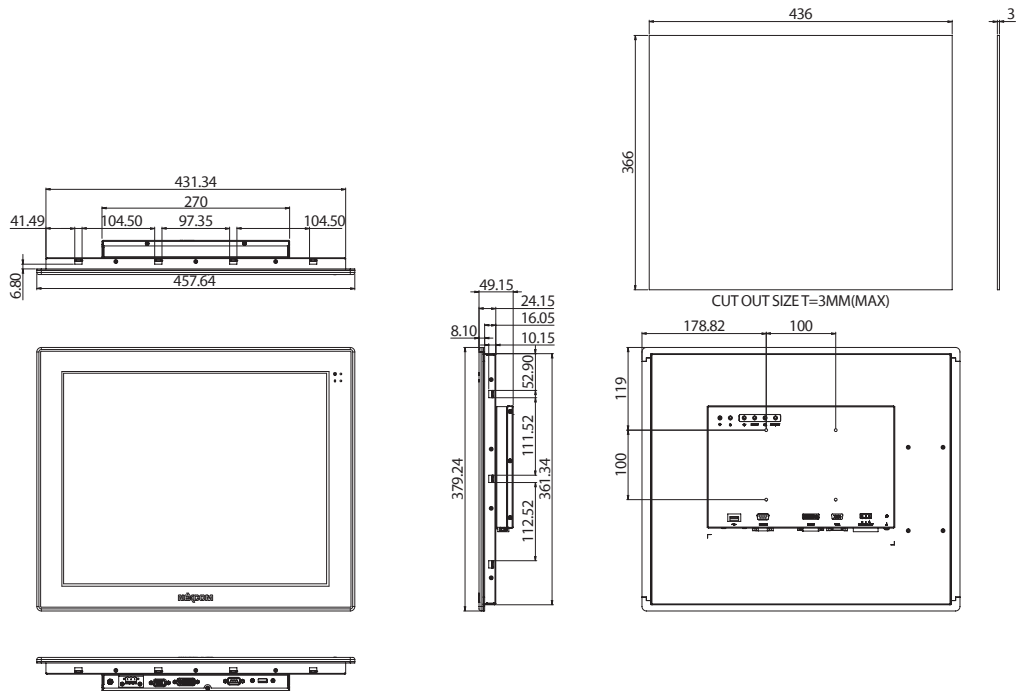

## Ordering Information

### ♦JM-APPD1900T

19" SXGA industrial 4:3 LED backlight flush touch monitor with VGA and DVI-D input, 12~24VDC input, RS232 and USB touch screen interfaces

### Options

- ♦12V, 60W AC/DC power adapter w/o power cord (P/N: 7400060031X00)
- ♦1.8m DVI-D male to DVI-D male cable (P/N: 60233DVI28X00 or P/N: 603DVI10007X00)

型號 : JM-APPD1900T

# JM-IPPD1600P

15.6" IP66 Heavy Industrial 16:9 WXGA Zero Bezel Flush Touch Monitor



## Main Features

- ♦ IP66 compliant and metal housing with robust aluminum front zero bezel for harsh environment
- ♦ 10 points P-Cap multi-touch with zero bezel flush front design
- ♦ 3 display input interface: analog VGA/DVI-D/DisplayPort
- ♦ Shares identical appearance with IPPC series
- ♦ Ultra slim in depth
- ♦ OSD multilanguage function
- ♦ All connectors with lock
- ♦ Mounting support: panel/wall/stand/VESA 100mm x 100mm
- ♦ Wide range power input 12~24VDC

## Product Overview

15.6" 16:9 LCD display IPPD 1600P is based on a ten points P-Cap multi-touch screen with resolution up to 1366 x 768 Panel. IPPD 1600P has system grade grounding protection which means chassis grounding and power grounding design to avoid in-rush current damage monitor. IPPD 1600P is ideal for space-critical environments where systems and displays are kept apart. In addition, IPPD 1600P adopts zero bezel flush panel design and has IP66 front panel. IPPD 1600P provides prevailing video interface: VGA, DVI-D and DisplayPort, supporting both digital and analog signals. Moreover, IPPD1600P supports 12~24VDC power input and offers panel mount and VESA mount, allowing users to choose the mounting method that meets their situation. IPPD 1600P is the best solution for NEXCOM NISE fanless computer, NVIS security surveillance series and APPC/IPPC panel PC when a second display is required.

## Specifications

### Panel

- ♦ LCD size: 15.6", 16:9
- ♦ Resolution: WXGA 1366 x 768
- ♦ Luminance: 300cd/m<sup>2</sup>
- ♦ Contrast ratio: 500
- ♦ LCD color: 16.7M
- ♦ Viewing angle: 80 (U), 80 (D), 85 (L), 85 (R)
- ♦ Backlight: LED

### Touch

- ♦ Ten points P-Cap (projected capacitive touch)
- ♦ Touch light transmission: 87%
- ♦ Anti-scratch surface: 7H hardness
- ♦ Touch interface: USB

### Rear I/O

- ♦ Touch interface port: USB with Lock
- ♦ Video port: VGA (1 x DB15)/DVI-D (1 x DVI-D connector)/DisplayPort
- ♦ DC power input connector: 3-pin PHOENIX terminal Blocks

### OSD Function

- ♦ OSD keypad
- ♦ Multilanguage OSD

### Mechanical & Environment

- ♦ Color: Pantone 432C/RAL 70 24 front bezel
- ♦ IP protection: IP66 front
- ♦ Mounting: panel/wall/stand/VESA 100mm x 100mm
- ♦ System with panel mounting kit w/o panel mounting hole
- ♦ Power input: 12~24VDC
- ♦ Power adapter: optional AC to DC power adapter (+12V, 60W)
- ♦ Vibration:
  - IEC 68 2-64
  - 2Grms @ sine, 5~500Hz, 1hr/axis (operating)
  - 2.2Grms @ random condition, 5~500Hz, 0.5hr/axis (non-operating)
- ♦ Shock:
  - IEC 68 2-27
  - HDD: 20G@wall mount, half sine, 11ms
- ♦ Operating temperature: -10°C to 60°C
- ♦ Storage temperature: -20°C to 75°C
- ♦ Operating humidity: 10%~90% relative humidity, non-condensing
- ♦ Dimension: 417.4 x 312.4 x 51.75mm
- ♦ Weight: 5.48Kg

### Certifications

- ♦ CE (including EN61000-6-1/EN61000-6-2/EN61000-6-3/EN61000-6-4)
- ♦ FCC Class B

## Dimension Drawing

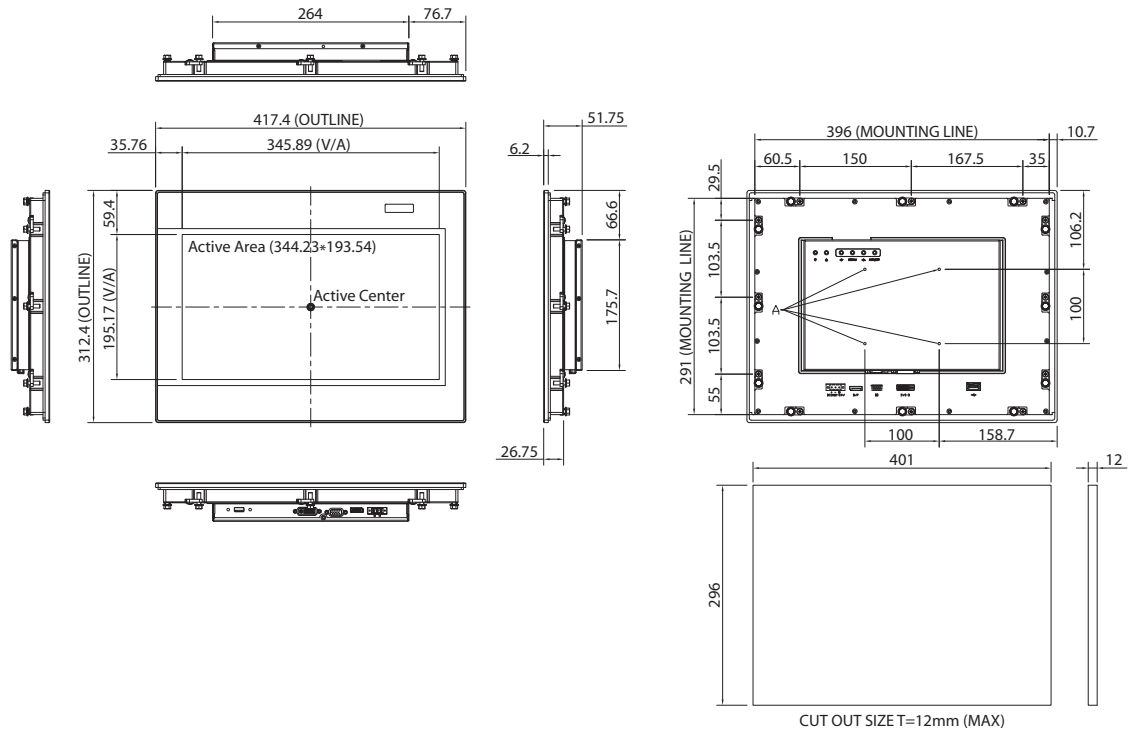

## Ordering Information

### Barebone

#### •JM-IPPD1600P

15.6" WXGA heavy industrial 16:9 LED backlight P-Cap touch monitor with VGA, DVI-D and DisplayPort input, 12~24VDC input

### Option

#### •12V, 60W AC/DC power adapter w/o power cord

(P/N: 7400060031X00)

#### •1.8m DVI-D male to DVI-D male cable

(P/N: 603DVI0007X00)

#### •1.8m DisplayPort cable (P/N: 6030000122X00)

型號 : JM-IPPD1600P

# 司騰達股份有限公司

自動化工業與跨國遠端連線的最佳選擇

Ewon Flexy205

VPN+IOT 物聯網模組

Ewon Cosy  
VPN 遠端連線



Anybus X-Gateway



CODESYS SoftPLC

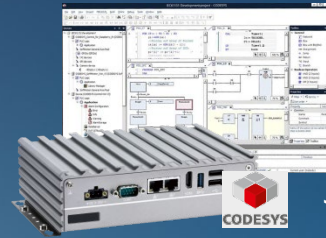

Jmobile HMI/SCADA IPC



## 工業 4.0 數位工廠與 工業物聯網解決方案

i4-SCADA IPC



WAGO750 Remote IO  
EtherCAT / PROFINET



SIEMENS ET 200SP  
PROFINET Remote IO



MR JET 系列  
EtherCAT 伺服馬達



eSMART Web HMI  
Esmart04/07/10

司騰達股份有限公司

台北營業所：235602 新北市中和區中山路 2 段 299 號 5 樓之 1

Tel : (02)-2242-1625 Fax : (02)-2242-1605

台中營業所：40760 台中市西屯區廣福路 186 號

Tel : (04)-2451-0611 Fax : (04)-2451-0612

E-mail : sales@bhp.com.tw

Line ID : @bhp.tw



司騰達股份有限公司  
BHP Industry Solution

LINE



官網



了解更多產品詳細資訊請上官網查詢  
www.bhp.com.tw