



司騰達股份有限公司  
BHP Industry Solution



EtherNet/IP

CC-Link



CANopen



Now with ...  
CPC UA



DeviceNet



# 司騰達股份有限公司

HMS 台灣總代理 – Remote Access 跨國遠端連線與自動化工業的最佳選擇

司騰達公司致力於推廣數位化工廠和 IIoT 工業物聯網的解決方案，並與歐洲最先進的公司 – HMS 集團合作，同時透過引進更多歐美的技術能量，提供客戶關於工業 4.0 的顧問諮詢服務，並將教育與產業連結，協助台灣產業逐步完成從現場設備、生產資訊、通訊 IoT 的垂直整合，並整合 M2M 工業總線與軟體開發，從而實現數位化工廠與自動化機械領域的創新。



司騰達聯絡訊息

臺北客服專線：(02)-2242-1625

台中客服專線：(04)-2451-0611

客服信箱：sales@bhp.com.tw

Line ID：@bhp.tw

www.bhp.com.tw

# EKI-6333AC-2G Series

## IEEE 802.11 a/b/g/n/ac Wi-Fi AP



### Features

- Supports 802.11ac MIMO 2x2
- WLAN transmission rate up to 1167 Mbps
- Supports secure access with WEP, 802.1x, WPA/WPA2-Personal, WPA/WPA2-Enterprise
- Provides Web-based configuration
- Supports dual bands 2.4/5GHz concurrent
- IP55 waterproof certification

### Introduction

The EKI-6333AC-2G is a feature-rich wireless AP providing reliable wireless connectivity for industrial environments. The PoE injector enhances flexibility in deployment of this AP even where the DC power supply is hard to fulfill. As a 802.11n compliant device, EKI-6333AC-2G provides a data rate that is six times higher than legacy 802.11g devices.

With the support of STP, WMM and IGMP snooping protocols, EKI-6333AC-2G improves the reliability of wireless connectivity, especially in applications requiring high reliability and throughput data transmission. To secure the wireless connection, EKI-6333AC-2G implements the latest encryption technologies, including WPA2/WPA/802.1x for powerful security authentication.

### Specifications

#### Ethernet Communications

- **Port Type** RJ45
- **No. of Ports** 2
- **Speed** 10/100/1000 Mbps

#### Wireless LAN Communications

- **Compatibility** 2.4GHz: IEEE 802.11 b/g/n  
5GHz: IEEE 802.11 a/n/ac
- **Speed** 5GHz: 867Mbps, 2.4GHz:300Mbps (Max)
- **Network Mode** Infrastructure
- **Free Space Range** Open space 100 m
- **Wireless Security** WEP, WPA/WPA2-Personal, WPA/WPA2-Enterprise

#### Software

- **Management** Telnet, FTP, SNMP, Web UI, SSH
- **Wireless** Radio on/off, WMM, Output Power Control, Beacon Interval, RTS/CTS threshold, DTIM Interval
- **Operation Modes** Access Point mode, Client, Repeater
- **Configuration** Web Browser
- **Protocol** ARP, ICMP, IPv4, IPv6, TCP, UDP, DHCP Client, DHCP Server, Auto IP, Telnet, DNS, SNMP, HTTP, DMZ, PPPoE, VPN Passthrough, Telnet Server, SSH Server, FTP Server, QoS

#### Antenna

- Default with 4 x external 5 dBi Omni antenna
- 4 x Reverse SMA connectors for SMA antenna

#### Data Rates

- **802.11b** 11M, 5.5M, 2M, 1Mbps
- **802.11a/g** 54M, 48M, 36M, 18M, 12M, 9M, 6Mbps
- **802.11n** HT20 MCS0~15 / HT40 MCS0~15
- **802.11ac** VHT80 MCS0~9

#### Mechanics

- **Enclosure** Plastic
- **Mounting** Wall, Pole
- **Dimensions (W x H x D)** 191.6 x 114.3 x 47.7 mm (7.54" x 4.49" x 1.88")
- **Weight** 0.5kg

#### General

- **LED Indicators** System: Power  
WLAN: Link/Active  
LAN: Link/Active

#### Power Requirements

- **Power Input** DC 24 V / 1A; POE Adapter 100 V ~ 240 V
- **Power Connector** RJ45, Passive 24V PoE
- **Power Consumption** 15W

#### Environment

- **Operating Temperature** -20 ~ 60°C (-4 ~ 140°F)
- **Storage Temperature** -30 ~ 80°C (-22 ~ 176°F)
- **Operating Humidity** 10 ~ 95% RH

#### Regulatory Approvals

- **EMC** CE, FCC Part 15 Subpart B

## Dimensions

Unit: mm [inch]

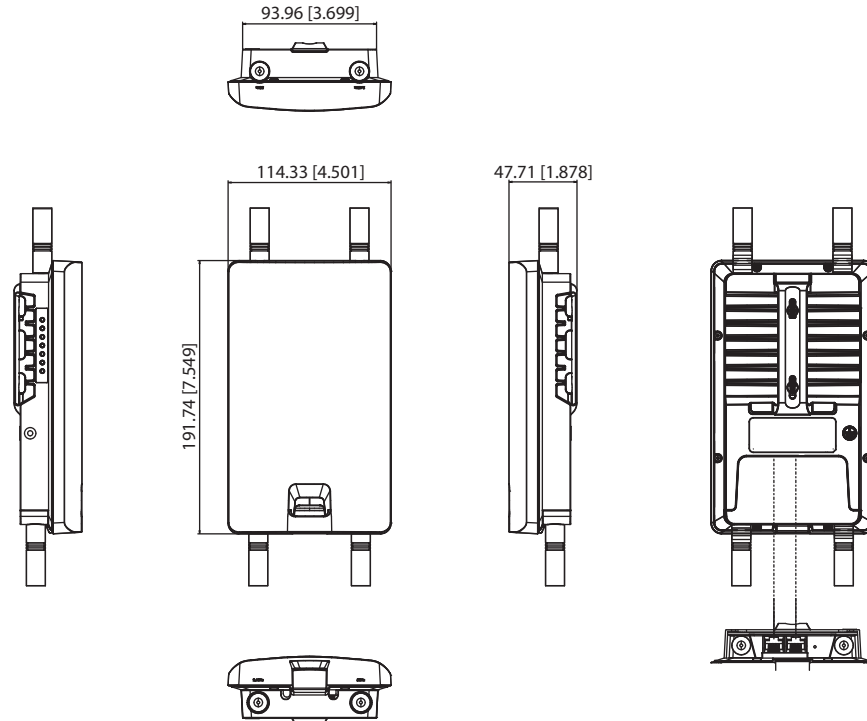

**Panel Cut-out Dimensions: 114.33 x 191.74 x 47.71 mm (4.5" x 7.5" x 1.8")**

### Wireless Transmission Rates (Non-EU SKU)

- **Transmitted Power\***
  - 802.11a 25.4 dBm@6Mbps
  - 802.11b: 25.8 dBm
  - 802.11g: 25.6 dBm@6Mbps
  - 802.11n HT20(2.4GHz): 25.6 dBm@MCS0/8/16
  - 802.11n HT40(2.4GHz): 20.7 dBm@MCS0/8/16
  - 802.11n HT20(5GHz): 25.2 dBm@MCS0/8/16
  - 802.11n HT40(5GHz): 25.3 dBm@MCS0/8/16
  - 802.11ac VHT80: 23.1dBm @MCS0
- **Receiver Sensitivity**
  - 802.11a -92 dBm@6Mbps, -75 dBm@54Mbps
  - 802.11b: -96 dBm@1Mbps, -88 dBm@11Mbps
  - 802.11g: -91.5 dBm@6Mbps, -75 dBm@54Mbps
  - 802.11n HT20(2.4GHz): -91 dBm@MCS0, -73.5 dBm@MCS7
  - 802.11n HT40(2.4GHz): -88 dBm@MCS0, -71.5 dBm@MCS7
  - 802.11n HT20(5GHz): -91.5 dBm@MCS0, -72.5 dBm@MCS7
  - 802.11n HT40(5GHz): -88 dBm@MCS0, -70.5 dBm@MCS7
  - 802.11ac VHT80 -86 dBm @MCS0; -61 dBm @MCS9

\*Note: The listed value is the target power calibrated in the card. The actual power will vary depending on each country's regulation

### Ordering Information

- **EKI-6333AC-2G-A** 802.11 a/b/g/n/ac Wireless AP/Client (US Power cord include)
- **EKI-6333AC-2G-EU-A** 802.11 a/b/g/n/ac Wireless AP/Client (EU Power cord include)



# 司騰達股份有限公司

自動化工業與跨國遠端連線的最佳選擇

Ewon Flexy205

VPN+IOT 物聯網模組

Ewon Cosy131

VPN 遠端連線



Anybus X-Gateway



CODESYS SoftPLC

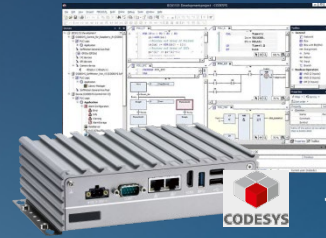

Jmobile HMI/SCADA IPC



## 工業 4.0 數位工廠與 工業物聯網解決方案

i4-SCADA IPC



WAGO750 RemoteIO

EtherCAT  
PROFINET



SIEMENS ET 200SP  
PROFINET Remote Io



SDP 系列  
EtherCAT 伺服馬達



eSMART Web HMI  
Esmart04/07/10

## 司騰達股份有限公司

台北營業所：235602 新北市中和區中山路 2 段 299 號 5 樓之 1

Tel：(02)-2242-1625 Fax：(02)-2242-1605

台中營業所：40760 台中市西屯區廣福路 186 號

Tel：(04)-2451-0611 Fax：(04)-2451-0612

E-mail：sales@bhp.com.tw

Line ID：@bhp.tw



司騰達股份有限公司  
BHP Industry Solution

LINE



官網



了解更多產品詳細資訊請上官網查詢  
www.bhp.com.tw