



司騰達股份有限公司
BHP Industry Solution



EtherNet/IP

CC-Link



CANopen



Now with ...
CPC UA

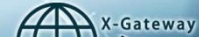

DeviceNet



司騰達股份有限公司

HMS 台灣總代理 – Remote Access 跨國遠端連線與自動化工業的最佳選擇

司騰達公司致力於推廣數位化工廠和 IIoT 工業物聯網的解決方案，並與歐洲最先進的公司 – HMS 集團合作，同時透過引進更多歐美的技術能量，提供客戶關於工業 4.0 的顧問諮詢服務，並將教育與產業連結，協助台灣產業逐步完成從現場設備、生產資訊、通訊 IoT 的垂直整合，並整合 M2M 工業總線與軟體開發，從而實現數位化工廠與自動化機械領域的創新。

LINE



官網



司騰達聯絡訊息

臺北客服專線：(02)-2242-1625

台中客服專線：(04)-2451-0611

客服信箱：sales@bhp.com.tw

Line ID：@bhp.tw

www.bhp.com.tw

EKI-1642I

Industrial Cellular Router



Features

- 4G LTE cellular connectivity with dual SIM card design
- Cellular/Ethernet uplink failover
- Supports NAT, router, and bridge network types
- Supports IPsec, OpenVPN, PPTP, L2TP, GRE VPN tunnel
- Supports SMS/SNMP/e-mail remote management
- Wide operating temperature
- Compact size for installation

Introduction

The EKI-1642I industrial cellular router provides secure and stable Internet connectivity. It supports various network protocols, NAT, firewall, and routing features while presenting a compact design. In addition to features such as automatic failover for wired/wireless networks, the EKI-1642I provides wireless connectivity for industrial and commercial networks where building up network infrastructure may be impractical. Under the high throughput of 150 Mbps with LTE CAT4 and with a secure VPN tunnel, the EKI-1642I allows you to establish a remote branch and surveillance network that offers stable performance.

Specifications

Standard Support

- **WAN** WAN cellular, Ether-WAN, Wi-Fi (optional), and failover support
- **LAN** 1(2) x RJ45 FE (EKI-1642I)
1(2) x RJ45 FE (EKI-1642WI)
- **SIM** Dual SIM Card (Failover / Failback)
- **Cellular Band** LTE: Band1/3/8/38/39/40/41
UMTS: Band1/8
TD SCDMA: Band34/39
- **SDcard** log storage
- **(Optional)** GPS
- **(Optional)** Wi-Fi
Standard: IEEE 802.11b/g/n
Mode: AP router
Functions: WMM
Security: WEP, WPA, WPA2, WPA-PSK, WPA2-PSK, 802.1x

Physical Specifications

- **Power** 5 ~ 18 V_{DC} (DC Jack)
Package with power adapter (5 V_{DC} @ 2 A)
- **Dimensions (L x W x H)** 93 x 90 x 27 mm
- **Mounting** Wall

Environment

- **Operating Temp.** -30 ~ 70°C
- **Storage Temperature** -40 ~ 85°C (-40 ~ 184°F)
- **Humidity** 10% ~ 95% non-condensing

Antenna

- 2 x SMA(F) for cellular connectivity
- 2 x 3dBi 3G/LTE antennas
- 1 x 3dBi Wi-Fi antenna (optional)

Other Features

- **Management** Web, Telnet CLI, command script, TR-069, SNMPv3 standard
- **Security** VPN: IPsec, OpenVPN, PPTP, L2TP, GRE
Firewall: SPI firewall with stealth mode, IPS
Access Control: Packet filter, URL blocking, MAC filter
- **VLAN** Port-based, tag-based VLAN
- **Routing** Static, Dynamic: RIP1/RIP2, OSPF, BGP
- **Port Forwarding** Virtual server, virtual computer, DMZ, VPN pass-through
- **Cellular Toolkit** Data usage, SMS, SIM PIN, network scan
- **Event Handling** User-defined event management/notification; SMS, mail, syslog, SNMP trap
- **Diagnostics** Packet analyzer, diagnostics tools

Dimensions

Unit: mm [in.]

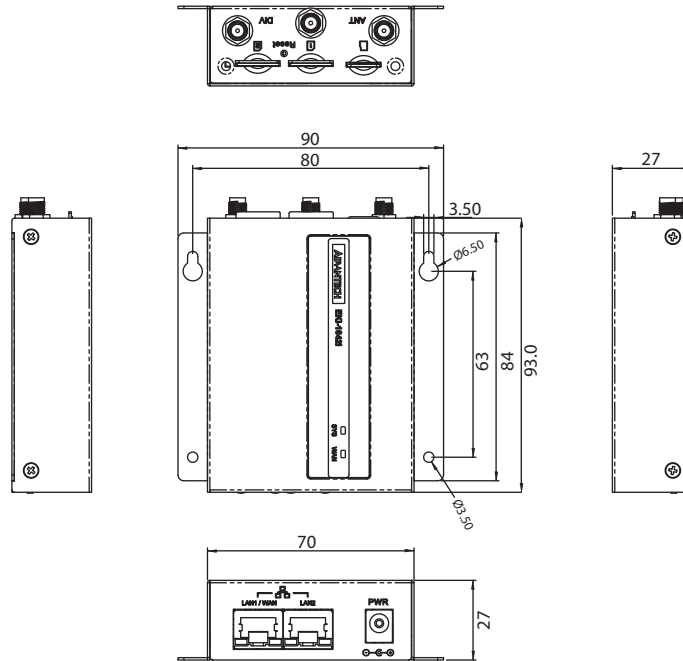

Ordering Information

- EKI-1642I-A Industrial LTE Router w/GPS
- EKI-1642WI-A Industrial LTE Router w/Wi-Fi

司騰達股份有限公司

自動化工業與跨國遠端連線的最佳選擇

Ewon Flexy205

VPN+IOT 物聯網模組

Ewon Cosy131

VPN 遠端連線



Anybus X-Gateway



CODESYS SoftPLC

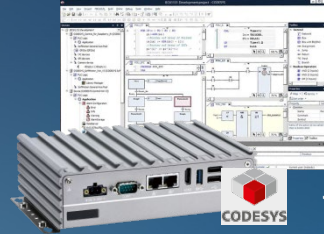

Jmobile HMI/SCADA IPC



工業 4.0 數位工廠與 工業物聯網解決方案

i4-SCADA IPC



WAGO750 RemoteIO

EtherCAT
PROFINET



SIEMENS ET 200SP
PROFINET Remote IO



SDP 系列
EtherCAT 伺服馬達



eSMART Web HMI
Esmart04/07/10

司騰達股份有限公司

台北營業所：235602 新北市中和區中山路 2 段 299 號 5 樓之 1

Tel：(02)-2242-1625 Fax：(02)-2242-1605

台中營業所：40760 台中市西屯區廣福路 186 號

Tel：(04)-2451-0611 Fax：(04)-2451-0612

E-mail：sales@bhp.com.tw

Line ID：@bhp.tw



司騰達股份有限公司
BHP Industry Solution

LINE



官網



了解更多產品詳細資訊請上官網查詢
www.bhp.com.tw